



# South Bay Foundry

WWW.SOUTHBAYFOUNDRY.COM

PHONE: (619) 956-2780 FAX: (619) 956-2788

## D0360-1.5SQ

60"x60" SLC STYLE TREE GRATE

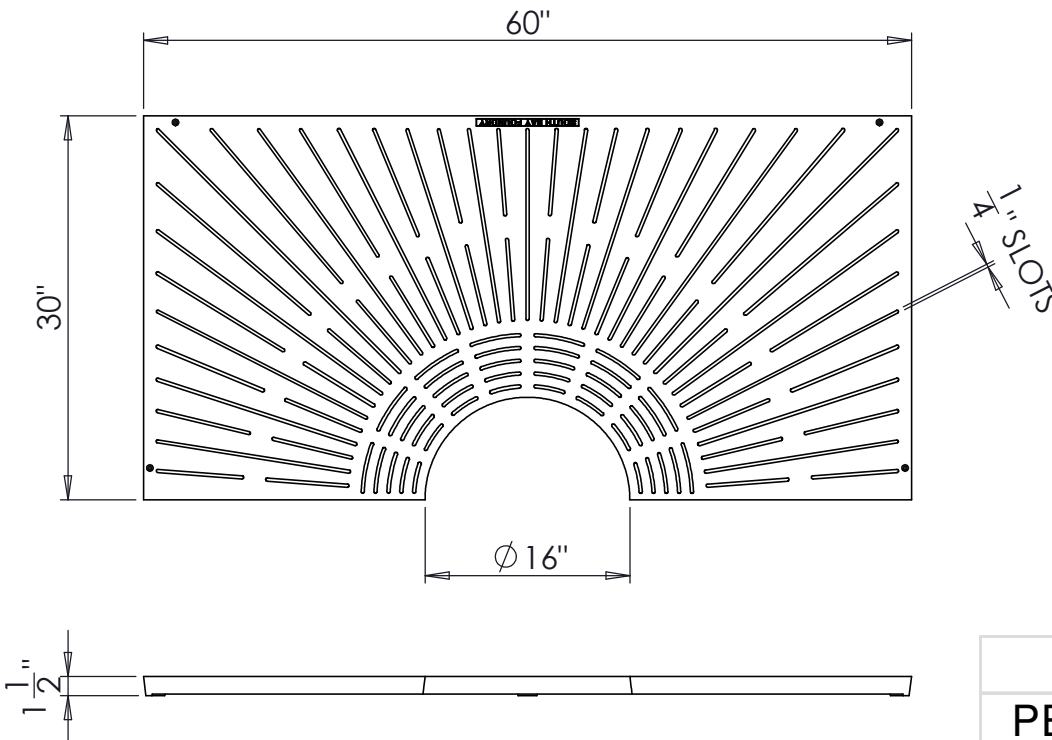
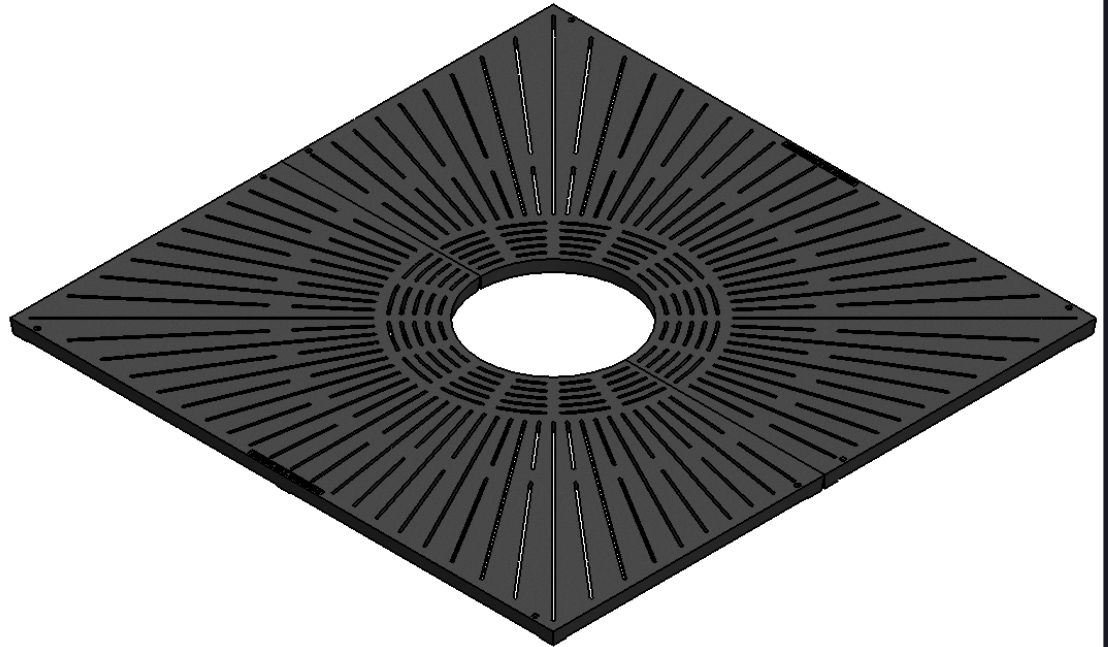

WEIGHT	
PER SET	640 LB

### GENERAL INFORMATION

- \*MATERIAL: CAST IRON, DUCTILE IRON, OR ALUMINUM
- \*FINISHES AVAILABLE: BARE, PAINTED, POWDER COATED, OR SHARK GRIP
- \*APPROXIMATE TREE OPENING: Ø 16", Ø 19", Ø 22", Ø 25", OR Ø 28"

### APPROVED

BY:

TITLE:

AGENCY:

DATE:

6/4/2013