



# South Bay Foundry

WWW.SOUTHBAYFOUNDRY.COM

PHONE: (619) 956-2780 FAX: (619) 956-2788

## D093660-1.5SQ

36"x60" STC STYLE TREE GRATE

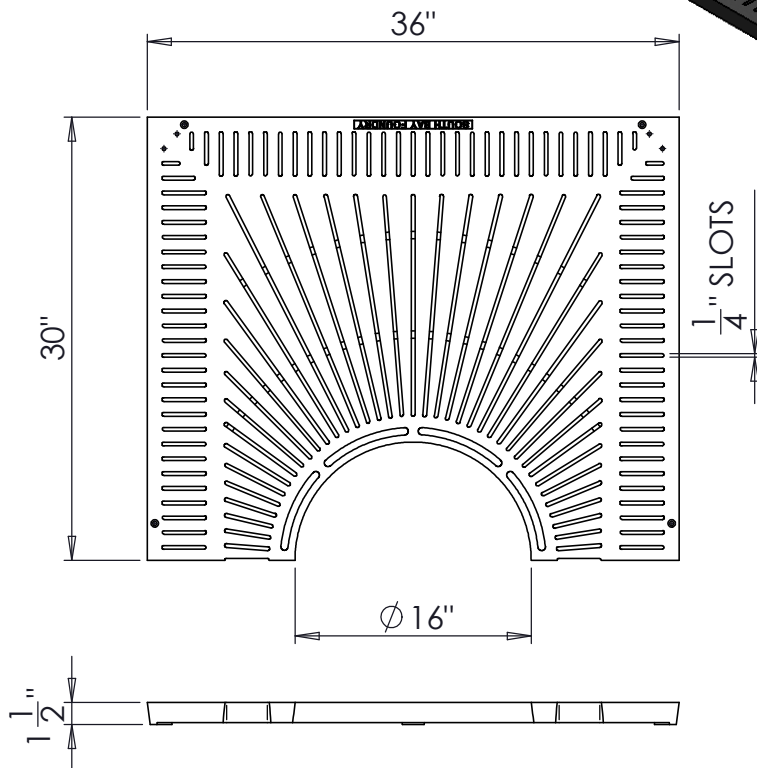
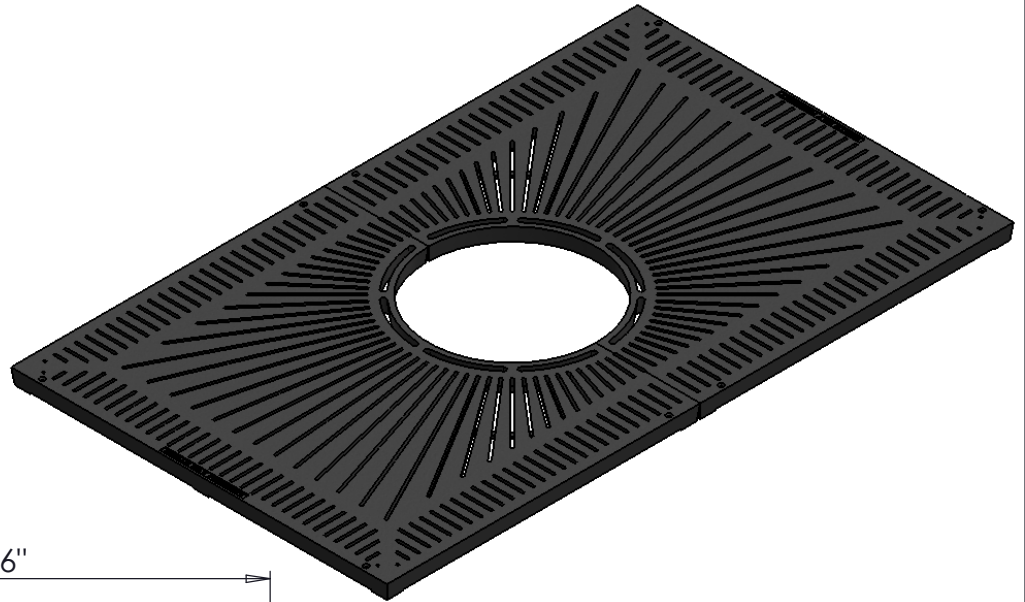

WEIGHT	
PER SET	336 LB

### GENERAL INFORMATION

- \*MATERIAL: CAST IRON, DUCTILE IRON, OR ALUMINUM
- \*FINISHES AVAILABLE: BARE, PAINTED, POWDER COATED, OR SHARK GRIP
- \*APPROXIMATE TREE OPENING: Ø 16" OR Ø 18"

### APPROVED

BY:

TITLE:

AGENCY:

DATE:

6/4/2013