



South Bay Foundry

WWW.SOUTHBAYFOUNDRY.COM

PHONE: (619) 956-2780 FAX: (619) 956-2788

D2048-1.5SQ

48"x48" 3D STYLE TREE GRATE

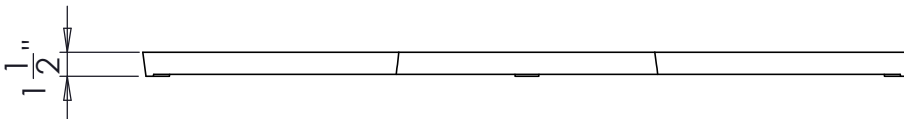
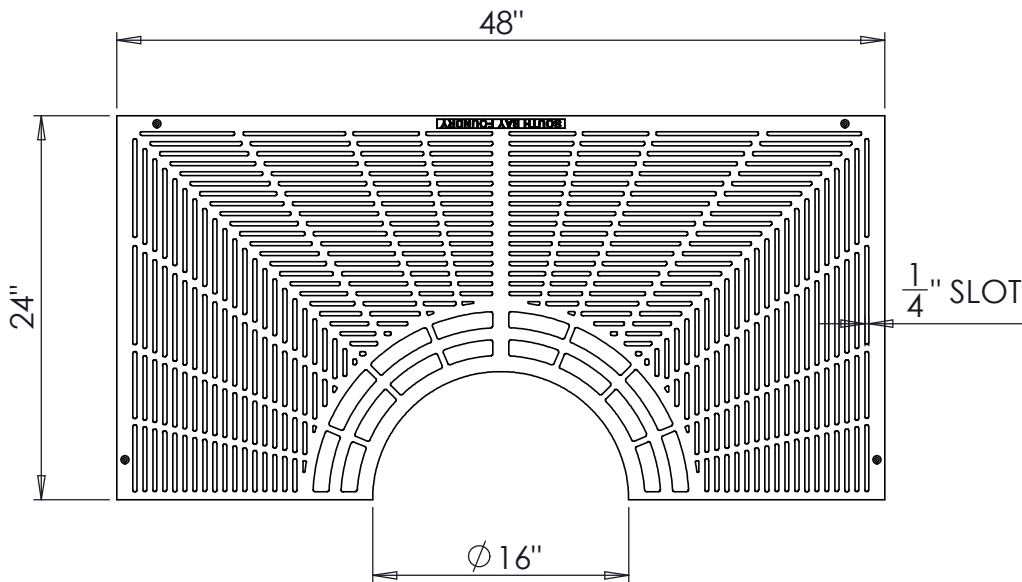
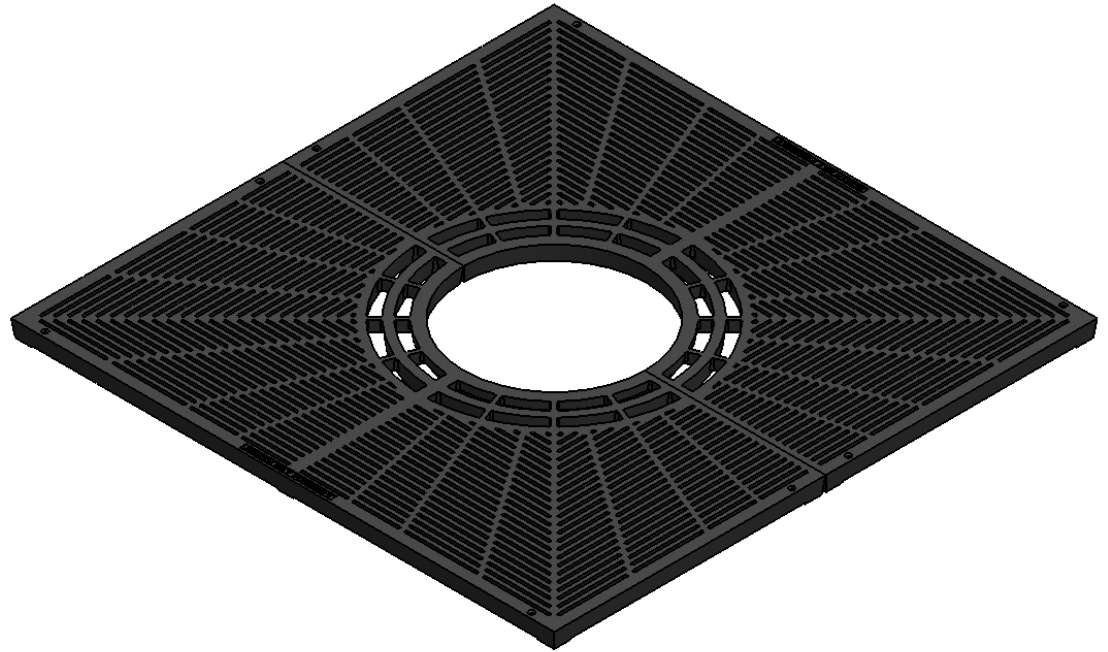

WEIGHT	
PER SET	270 LB

GENERAL INFORMATION

- *MATERIAL: CAST IRON, DUCTILE IRON, OR ALUMINUM
- *FINISHES AVAILABLE: BARE, PAINTED, POWDER COATED, OR SHARK GRIP
- *APPROXIMATE TREE OPENING: Ø 16", Ø 20", OR Ø 23.5"

APPROVED

BY:

TITLE:

AGENCY:

DATE:

6/4/2013