



South Bay Foundry

WWW.SOUTHBAYFOUNDRY.COM

PHONE: (619) 956-2780 FAX: (619) 956-2788

SBF 1201

6 3/4" x 4 1/2" FRAME AND LID
MONUMENT

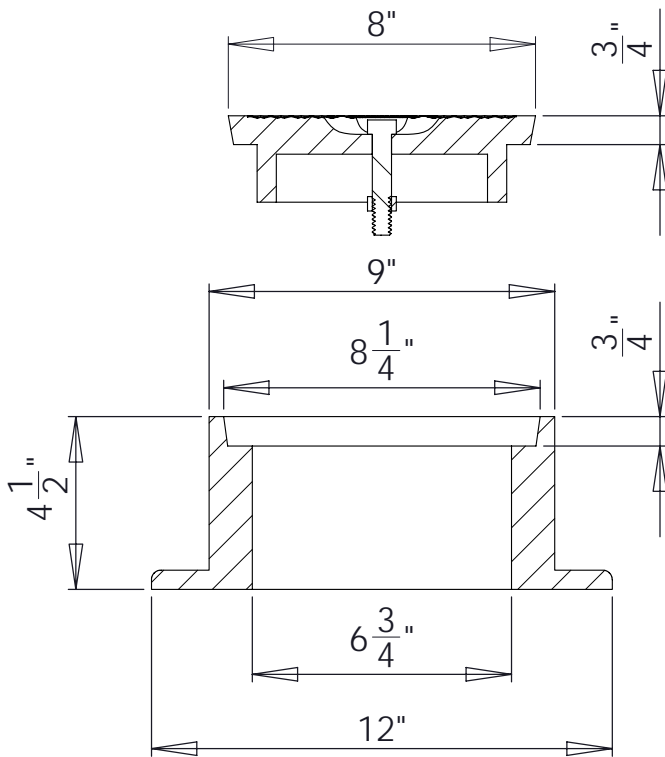
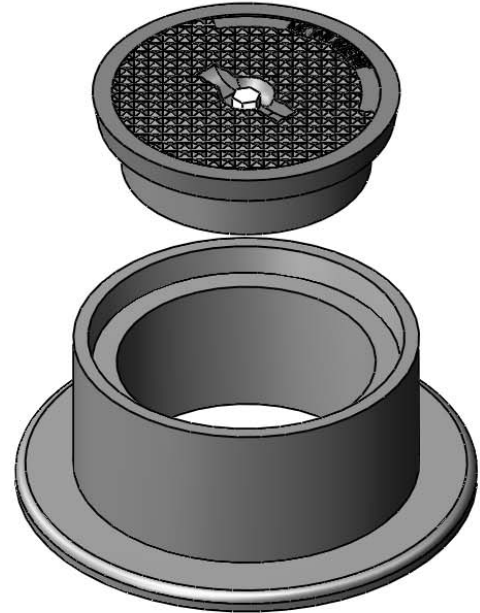
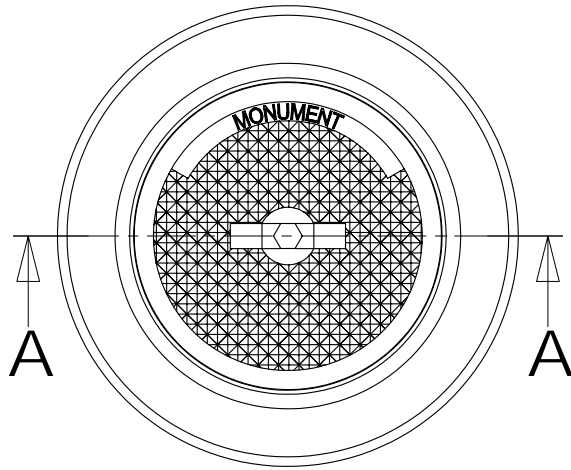

SECTION A-A

SET WEIGHT	
FRAME	37 LB
LID	13 LB
TOTAL	50 LB

GENERAL INFORMATION

- *MATERIALS CONFORM TO ASTM A48 CLASS 35B
- *CASTINGS SHALL BE DIPPED IN BLACK BITUMINOUS PAINT
- *BEARING SURFACES MACHINED FOR CLOSE, QUIET FIT
- *FRAME AND LID MEETS H-20 WHEEL LOADING

APPROVED

BY:

TITLE:

AGENCY:

DATE: