



South Bay Foundry

WWW.SOUTHBAYFOUNDRY.COM

PHONE: (619) 956-2780 FAX: (619) 956-2788

SBF C1510 / C1515

18" FRAME AND GRATE
FLANGE UP
RCP DROP IN

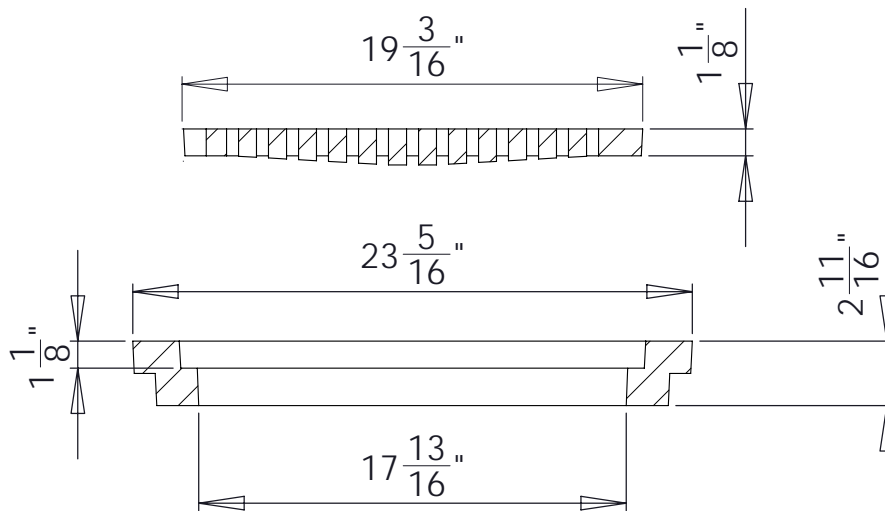
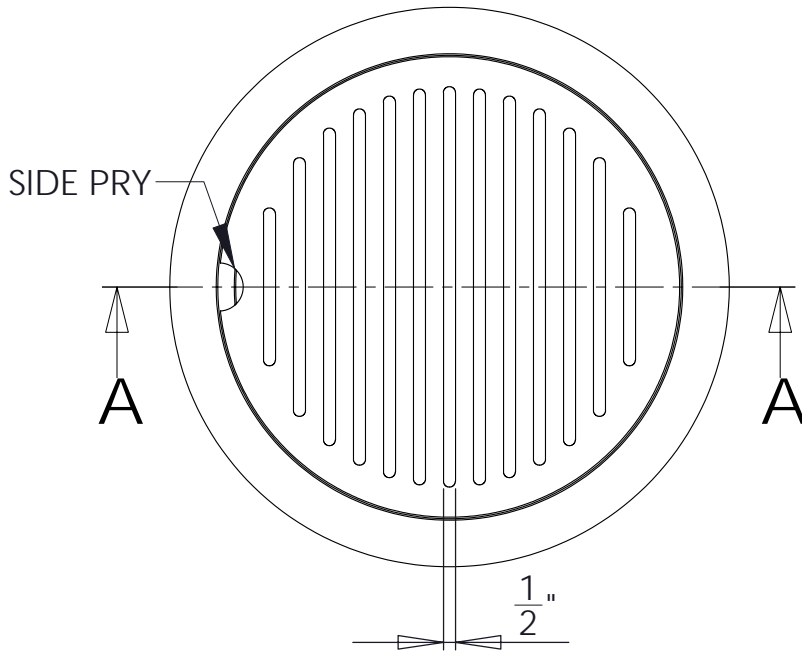

SET WEIGHT	
FRAME	40 LB
GRATE	66 LB
TOTAL	106 LB

SECTION A-A

GENERAL INFORMATION

- *MATERIALS CONFORM TO ASTM A48 CLASS 35B
- *BEARING SURFACES MACHINED FOR CLOSE, QUIET FIT
- *CASTINGS SHALL BE DIPPED IN BLACK BITUMINOUS PAINT
- *FRAME AND GRATE EXCEEDS H-20 WHEEL LOADING

APPROVED

BY:

TITLE:

AGENCY:

DATE: