



South Bay Foundry

WWW.SOUTHBAYFOUNDRY.COM

PHONE: (619) 956-2780 FAX: (619) 956-2788

SBF 1133

30" MANHOLE
FRAME AND COVER

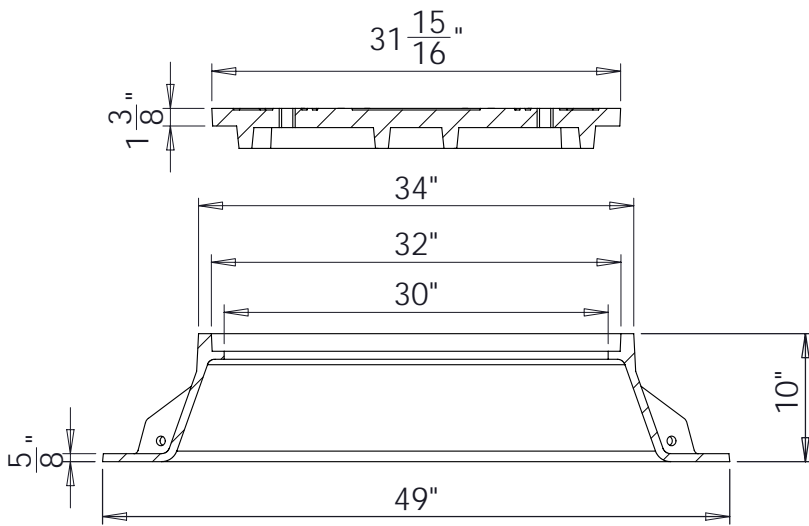
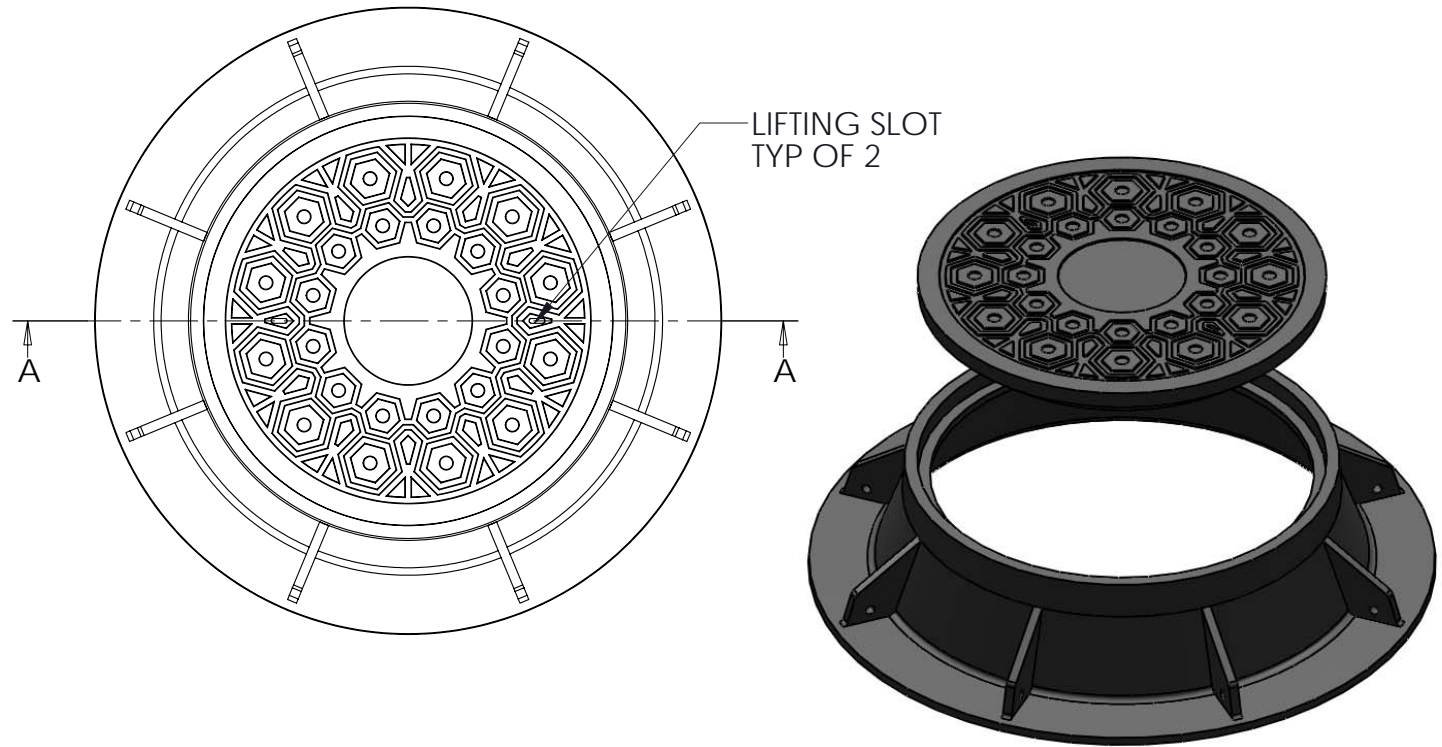

SECTION A-A

SET WEIGHT	
FRAME	400 LB
COVER	325 LB
TOTAL	725 LB

GENERAL INFORMATION

- *MATERIAL: GREY CAST IRON ASTM A48 CLASS 30B
- *BEARING SURFACES MACHINED FOR CLOSE, QUIET FIT
- *FINISH: DIPPED IN BLACK BITUMINOUS PAINT
- *MEETS H - 20 WHEEL LOAD REQUIREMENTS

APPROVED

BY:

TITLE:

AGENCY:

DATE: