



# South Bay Foundry

WWW.SOUTHBAYFOUNDRY.COM

PHONE: (619) 956-2780 FAX: (619) 956-2788

## SBF 1310

CITY OF ENCINITAS SEWER  
A1000 / A1050-2

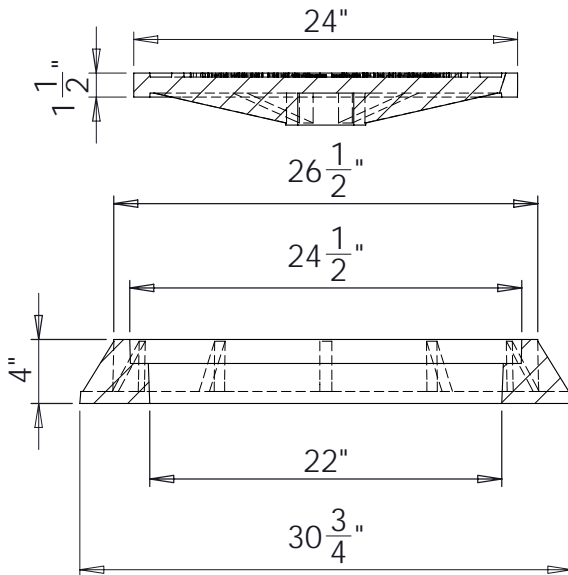
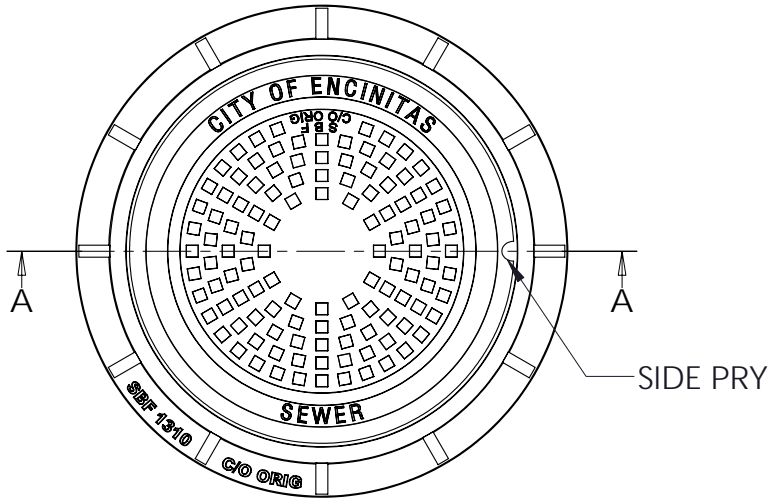

SECTION A-A

### GENERAL INFORMATION

- \*MATERIAL: GREY CAST IRON ASTM A48 CLASS 30B
- \*BEARING SURFACES MACHINED FOR CLOSE, QUIET FIT
- \*FINISH: DIPPED IN BLACK BITUMINOUS PAINT
- \*MEETS H-20 WHEEL LOAD REQUIREMENTS

### APPROVED

BY:

TITLE:

AGENCY:

DATE:

7/3/2012