



South Bay Foundry

WWW.SOUTHBAYFOUNDRY.COM

PHONE: (619) 956-2780 FAX: (619) 956-2788

SBF 1530

22" MANHOLE
FRAME AND COVER
SANITARY SEWER

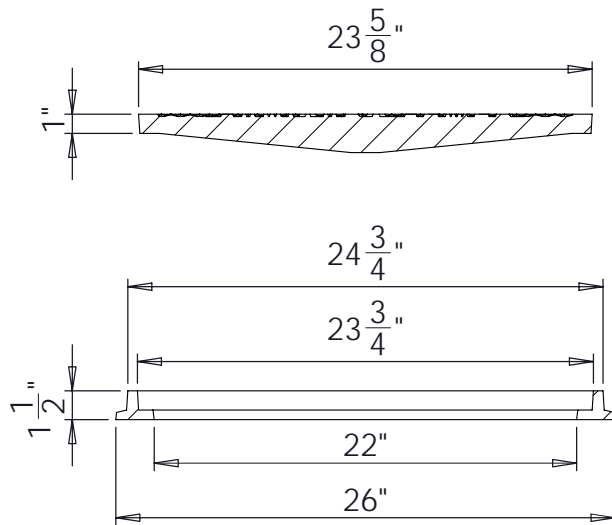
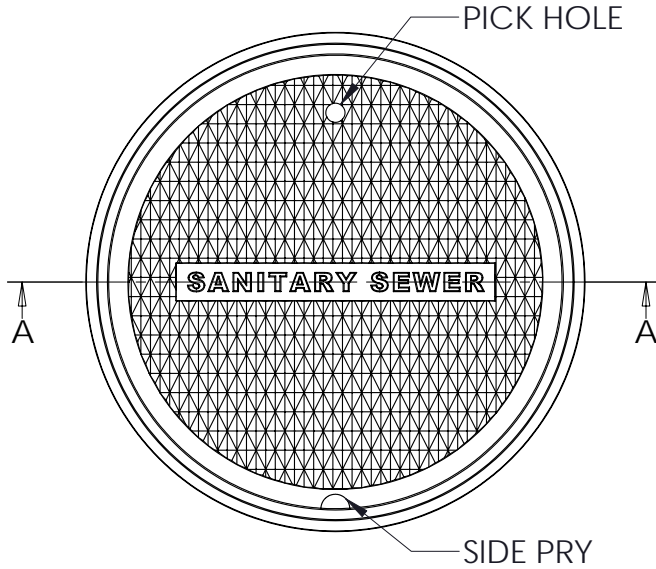

SECTION A-A

ID#	A4330	A4390	
SIZE	22" (F)	23-5/8" (C)	TOTAL
WEIGHT	30 LB	100 LB	130 LB

GENERAL INFORMATION

- *MATERIAL: GREY CAST IRON ASTM A48 CLASS 30B
- *BEARING SURFACES MACHINED FOR CLOSE, QUIET FIT
- *FINISH: DIPPED IN BLACK BITUMINOUS PAINT
- *MEETS H-20 WHEEL LOAD REQUIREMENTS

APPROVED

BY:

TITLE:

AGENCY:

DATE: